

OPERATION AND MAINTENANCE MANUAL FOR MODEL M010FA18000TFA9728 MOTOR ASSEMBLY

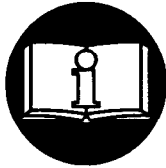

▲ WARNING

**IMPORTANT SAFETY INFORMATION ENCLOSED.
READ THIS MANUAL BEFORE OPERATING TOOL.**

**IT IS THE RESPONSIBILITY OF THE EMPLOYER TO PLACE THE INFORMATION
IN THIS MANUAL INTO THE HANDS OF THE OPERATOR.**

FAILURE TO OBSERVE THE FOLLOWING WARNINGS COULD RESULT IN INJURY.

PLACING TOOL IN SERVICE

- Always operate, inspect and maintain this tool in accordance with American National Standards Institute Safety Code for Portable Air Tools (ANSI B186.1)
- For safety, top performance, and maximum durability of parts, operate this tool at 90 psig (6.2 bar/620 kPa) maximum air pressure at the inlet with 1/4" (6 mm) inside diameter air supply hose.
- Always turn off the air supply and disconnect the air supply hose before installing, removing or adjusting any accessory on this tool, or before performing any maintenance on this tool.
- Do not use damaged, frayed or deteriorated air hoses and fittings.
- Be sure all hoses and fittings are the correct size and are tightly secured. See Dwg. TPD905-1 for a typical piping arrangement.
- Always use clean, dry air at 90 psig maximum air pressure. Dust, corrosive fumes and/or excessive moisture can ruin the motor of an air tool.
- Do not lubricate tools with flammable or volatile liquids such as kerosene, diesel or jet fuel.
- Do not remove any labels. Replace any damaged label.
- Always wear hearing protection when operating this tool.
- Keep hands, loose clothing and long hair away from rotating end of tool.
- Anticipate and be alert for sudden changes in motion during start up and operation of any power tool.
- Keep body stance balanced and firm. Do not overreach when operating this tool. High reaction torques can occur at or below the recommended air pressure.
- Tool accessories may continue to rotate briefly after throttle is released.
- Air powered tools can vibrate in use. Vibration, repetitive motions or uncomfortable positions may be harmful to your hands and arms. Stop using any tool if discomfort, tingling feeling or pain occurs. Seek medical advice before resuming use.
- Use accessories recommended by Ingersoll-Rand.
- The Throttle Valve Cap is under pressure from the Throttle Valve Spring. Use care when removing the Throttle Valve Cap. (On tools where applicable.)
- This tool is not designed for working in explosive atmospheres.
- This tool is not insulated against electric shock.

USING THE TOOL

- Always wear eye protection when operating or performing maintenance on this tool.

NOTICE

The use of other than genuine Ingersoll-Rand replacement parts may result in safety hazards, decreased tool performance, and increased maintenance, and may invalidate all warranties.

Repairs should be made only by authorized trained personnel. Consult your nearest Ingersoll-Rand Authorized Servicenter.

WARNING LABEL IDENTIFICATION



FAILURE TO OBSERVE THE FOLLOWING WARNINGS COULD RESULT IN INJURY.

	WARNING Always wear eye protection when operating or performing maintenance on this tool.
--	---

	WARNING Always wear hearing protection when operating this tool.
--	--

	WARNING Always turn off the air supply and disconnect the air supply hose before installing, removing or adjusting any accessory on this tool, or before performing any maintenance on this tool.
--	---

	WARNING Air powered tools can vibrate in use. Vibration, repetitive motions or uncomfortable positions may be harmful to your hands and arms. Stop using any tool if discomfort, tingling feeling or pain occurs. Seek medical advice before resuming use.
--	--

	WARNING Do not carry the tool by the hose.
--	--

	WARNING Do not use damaged, frayed or deteriorated air hoses and fittings.
--	--

	WARNING Keep body stance balanced and firm. Do not overreach when operating this tool.
--	--

	WARNING Operate at 90 psig (6.2 bar/ 620 kPa) Maximum air pressure.
--	---

PLACING TOOL IN SERVICE

LUBRICATION



IRAX No. 10P
IRAX No. 50P



IRAX No. 68 1LB

Always use an air line lubricator with these tools.
We recommend the following Filter-Lubricator-Regulator Unit:

For USA No. – IRAX No. C22-04-G00

After each two hours of operation, if an air line lubricator is not used, inject 1/2 to 1 cc of IRAX No. 10P Oil into the Air Inlet.

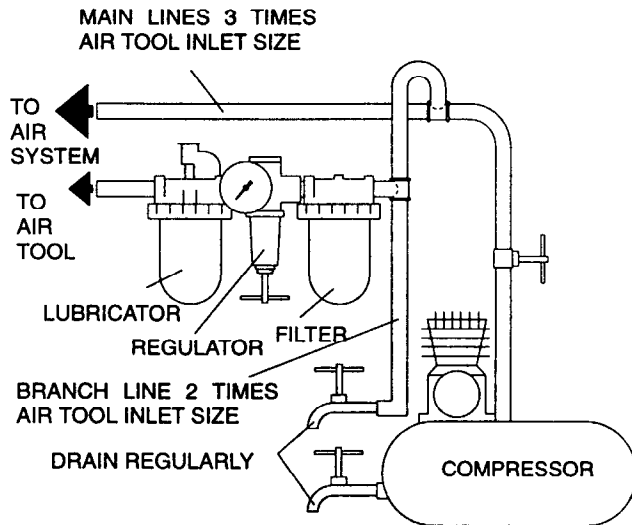

(Dwg. TPD905-1)

M010FA18000TFA9728 Motor Assembly

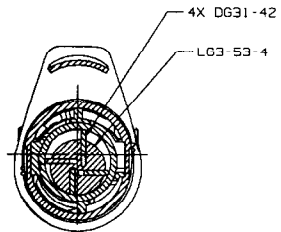
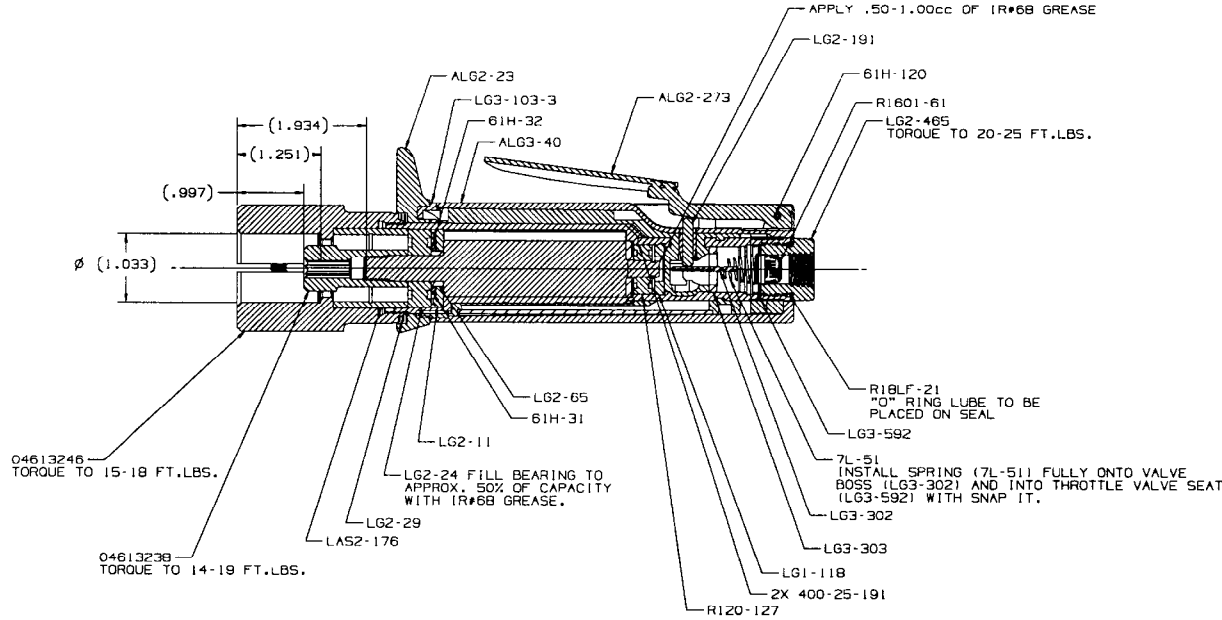

M010FA18000TFA9728 Motor Assembly

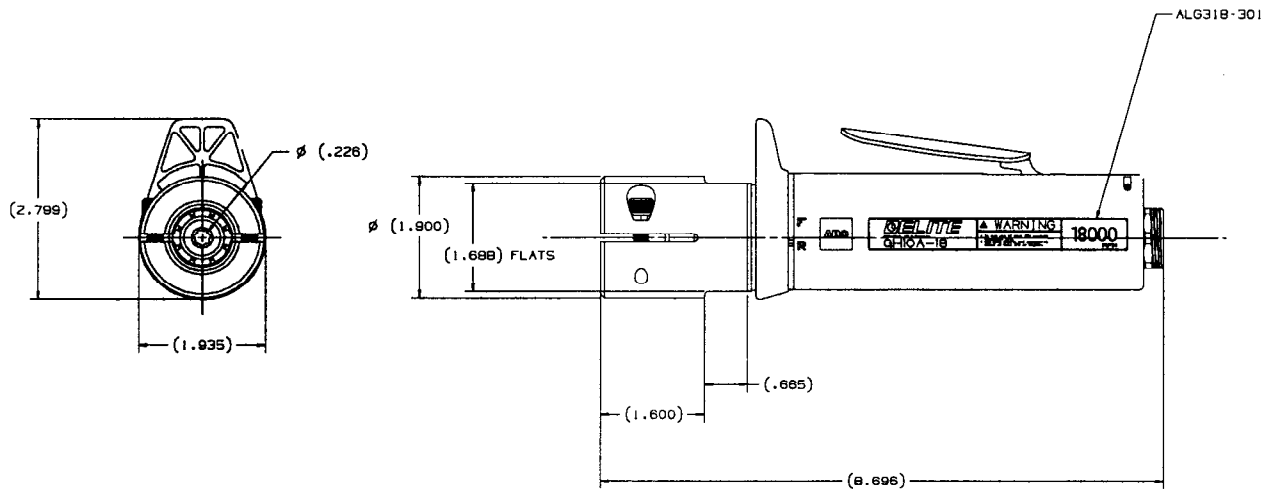
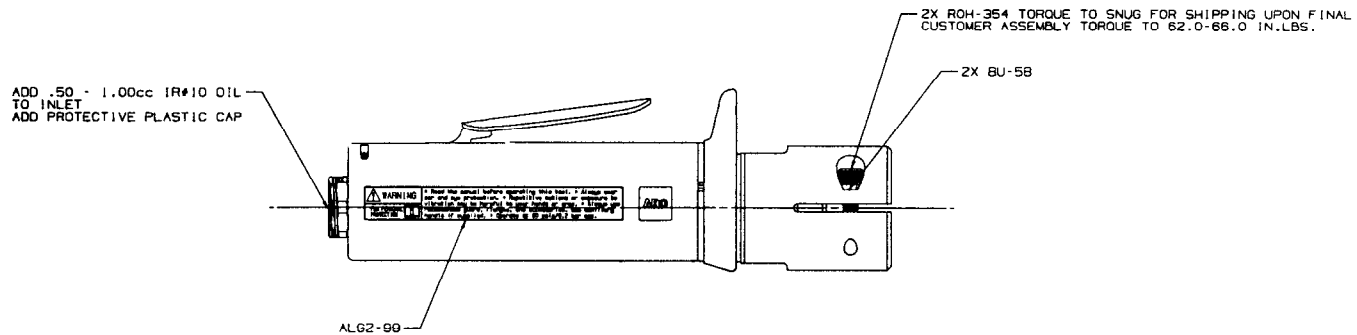

MAINTENANCE SECTION

TROUBLESHOOTING GUIDE

Trouble	Probable Cause	Solution
Low power or low free speed	Insufficient air pressure	Check air line pressure at the Inlet of the Tool. It must be 90 psig (6.2 bar/620 kPa).
	Clogged muffler elements	Disassemble the Tool and agitate bare Motor Housing and Flange in clean, suitable, cleaning solution. If elements cannot be cleaned, replace the Motor Housing and/or the Flange.
	Plugged Inlet Screen	Clean the Inlet Screen in clean, suitable, cleaning solution or replace the Screen.
	Worn or broken Vanes	Install a complete set of new Vanes.
	Loose Clamp Nut or Arbor Housing	Tighten the Nut or Housing to 20 to 25 ft-lb (27 to 34 Nm) torque.
	Worn or broken Motor Housing	Replace the Motor Housing.
	Internal air leakage in the Motor Housing indicated by high air consumption/low speed or air leaking out the front and rear exhaust simultaneously.	Replace the Motor Housing.
	Grit buildup under the Throttle Lever restricting full Throttle Valve Plunger movement.	Remove the Throttle Lever and clean the groove in the Motor Housing.
	Bent stem on Throttle Valve	Replace the Throttle Valve.
	Front Seal Cup Assembly dragging against the shield of the Front Rotor Bearing	Reposition the Front Seal Cup Assembly.
Excessive runout	Bent rotor hub	Replace the Rotor.
	Worn or damaged Front Rotor Bearing	Replace the Front Rotor Bearing.
Scoring of End Plate	Worn Front End Plate Spacer or Front End Plate	Install a new Front End Plate Spacer and Front End Plate.
	Worn Front Rotor Bearing	Install a new Front Rotor Bearing.

MAINTENANCE SECTION

TROUBLESHOOTING GUIDE

Trouble	Probable Cause	Solution
Leaky Throttle Valve	Dirt accumulation on Throttle Valve or Throttle Valve Seat	Disassemble, inspect and clean parts.
	Worn Throttle Valve or Throttle Valve Seat	Replace the Throttle Valve and/or Throttle Valve Seat.
	Excessive dirt build-up beneath the Throttle Lever	Clean out the slot area.
	Bent Throttle Valve Plunger	Replace the Plunger.
Exhausts at wrong direction	Incorrect orientation of the Flow Ring	Reverse the face of the Flow Ring against the Motor Housing.
Front Rotor Bearing runs hot	Incorrect installation of the Front Seal Cup Assembly	Reposition the Front Seal Cup Assembly flush with the face of the Front End Plate Spacer.
	Front End Plate Spacer rubbing the bore of the Front End Plate	Replace the Front End Plate and Front End Plate Spacer combination.
	Incorrect Front Rotor Bearing installation orientation	If a black stain or black hashmarks are not visible on the face of the Bearing when it is assembled with the End Plate and Rotor, the Bearing is installed backwards. If possible, remove the Bearing and install it correctly or replace the Bearing.
Slow tool idle	Bent or leaky Throttle Valve	Replace the Throttle Valve.
Air leakage around Flow Ring	Damaged, mutilated or missing Flange Clamp	Replace the Flange Clamp.
	Damaged Flow Ring	Replace the Flow Ring.
Rough operation/vibration	Improper lubrication or dirt buildup	Disassemble the Tool and clean in a clean, suitable, cleaning solution. Assemble the Tool and inject 3 cc of the recommended oil into the Inlet and run the Grinder long enough to coat the internal parts with the oil.
	Worn or broken Rear Rotor Bearing or Front Rotor Bearing	Replace the worn or broken Bearings. Examine the Front End Plate, Front End Plate Spacer Front Seal Cup Assembly and Rear Rotor Bearing Spacers and replace any damaged parts. If the rear end plate is damaged, replace the Rotor.

NOTICE

SAVE THESE INSTRUCTIONS. DO NOT DESTROY.

